



HGM9320CAN

HGM93XX MPU(CAN) series genset controllers are used for genset automation and monitor control system of single unit to achieve automatic start/stop, data measure, alarm protection and “three remote” (remote control, remote measuring and remote communication). The controller adopts large liquid crystal display (LCD) and selectable Chinese, English or other languages interface with easy and reliable operation.

Product Code : 6010032

Power Supply : DC(8-35)V

Case Dimensions : 237*172*45(mm)

Panel Cutout : 214*160(mm)

Operating Temp. : (-25~+70)°C

Weight : 0.85kg

COMPLETE DESCRIPTION

HGM93XX MPU(CAN) series genset controllers are used for genset automation and monitor control system of single unit to achieve automatic start/stop, data measure, alarm protection and “three remote” (remote control, remote measuring and remote communication). The controller adopts large liquid crystal display (LCD) and selectable Chinese, English or other languages interface with easy and reliable operation.

HGM93XX MPU(CAN) series genset controllers adopt 32 bits micro-processor technology with precision parameters measuring, fixed value adjustment, time setting and threshold adjusting and etc. The majority of parameters can be set using front panel and all the parameters can be set using PC (via USB port) and can be adjusted and monitored with the help of RS485 port. It can be widely used in a number of automatic genset control system with compact structure, simple connections and high reliability.

Performance and Characteristics

HGM9310 MPU(CAN), used for single automation systems, auto start/stop of the unit are performed with the help of remote signal.

HGM9320 MPU(CAN), has all functions of HGM9310 MPU(CAN) as well as automatic mains failure function (AMF), particularly well suited for single automation systems that include mains and generator.

Key characteristics

1. With ARM-based 32-bit SCM, highly integrated hardware, new reliability level.
2. 480x272 TFT LCD with backlight, multilingual interface (including English, Chinese or other languages) which can be chosen at the site, making commissioning convenient for factory personnel;
3. Improved LCD wear-resistance and scratch resistance due to hard screen acrylic;
4. Silicon panel and pushbuttons for better operation in high-temperature environment;
5. RS485 communication port enabling remote control, remote measuring, remote communication via ModBus protocol (RS485 communication port is needed);
6. Equipped with SMS (Short Message Service) function. When genset is alarming, controller can send short messages via SMS automatically to max. 5 telephone numbers. besides, generator status can be controlled and checked using SMS(GSM port is needed);
7. Equipped with CANBUS port and can communicate with J1939 genset. Not only can you monitoring frequently-used data (such as water temperature, oil pressure, speed, fuel consumption and so on) of ECU machine, but also control start, stop, raising speed and speed droop via CANBUS port(CAN BUS port is needed).
8. Suitable for 3-phase 4-wire, 3-phase 3-wire, single phase 2-wire, and 2-phase 3-wire systems with voltage 120/240V and frequency 50/60Hz;

9. Collects and shows 3-phase voltage, current, power parameter and frequency of generator or mains.
10. For Mains, controller has over and under voltage, over and under frequency, loss of phase and phase sequence wrong detection functions; For generator, controller has over and under voltage, over and under frequency, loss of phase, phase sequence wrong, over and reverse power, over current functions;
11. 3 fixed analog sensors (temperature, oil pressure and fuel level);
12. 2 flexible sensors can be set as temperature sensor, oil pressure sensor or level sensor;
13. Precision measure and display parameters about Engine,
14. Protection: automatic start/stop of the genset, ATS(Auto Transfer Switch) control with perfect failure indication and protection function;
15. All output ports are relay-out;
16. Parameter setting: parameters can be modified and stored in internal FLASH memory and cannot be lost even in case of power outage; most of them can be adjusted using front panel of the controller and all of them can be modified using PC via USB or RS485 ports.
17. More kinds of curves of temperature, oil pressure, fuel level can be used directly and users can define the sensor curves by themselves;
18. Multiple crank disconnect conditions (generator frequency, speed sensor, oil pressure) are optional;
19. Widely power supply range DC(8~35)V, suitable to different start battery voltage environment;
20. Event log, real-time clock, scheduled start & stop generator (can be set as start genset once a day/week/month whether with load or not);
21. PLC (programmable logic control) function allows for specific function can be user-defined.
22. Logon wallpaper and display time are user-defined.
23. Can be used on pumping units and as an indicating instrument (indicate and alarm are enable only, relay is inhibited);
24. With maintenance function. Actions (warning or shutdown) can be set when maintenance time out;
25. All parameters used digital adjustment, instead of conventional analog modulation with normal potentiometer, more reliability and stability;
26. Waterproof security level IP55 due to rubber seal installed between the controller enclosure and panel fascia;
27. Metal fixing clips enable perfect in high temperature environment;
28. Modular design, self-extinguishing ABS plastic enclosure, pluggable connection terminals and embedded installation way; compact structure with easy mounting;
29. Accumulative total run time and total electric energy of A and B. Users can reset it as 0 and re-accumulative the value which make convenience to users to count the total value as their wish.

PARAMETER LIST

Function Item	Parameter
Display	4.3 inches TFT-LCD (480*272)
Operation Panel	Silicon Rubber
Language	Chinese & English & Others
Digital Input	8
Relay Output	8
Analogue Input	5
AMF	●
AC System	1P2W/2P3W/3P3W/3P4W
Alternator Voltage	(15~360)V(ph-N)
Alternator Frequency	50/60Hz
kW/Amp Detecting & Display	●
Monitor Interface	RS485
Programmable Interface	USB/RS485
CANBUS(1939)	●
RTC & Event Log	●
Scheduled Start Genset	●
Maintenance	●
ULP	●
SMS	●
Can Expand Digital Input/Output Modules	●
DC Supply	DC(8-35)V
Case Dimensions(mm)	237*172*45

Function Item

Parameter

Panel Cutout(mm)

214*160

Operating Temp.

(-25~+70)°C

HGM9320CAN Typical Application

HGM9320MPU(CAN) typical application diagram

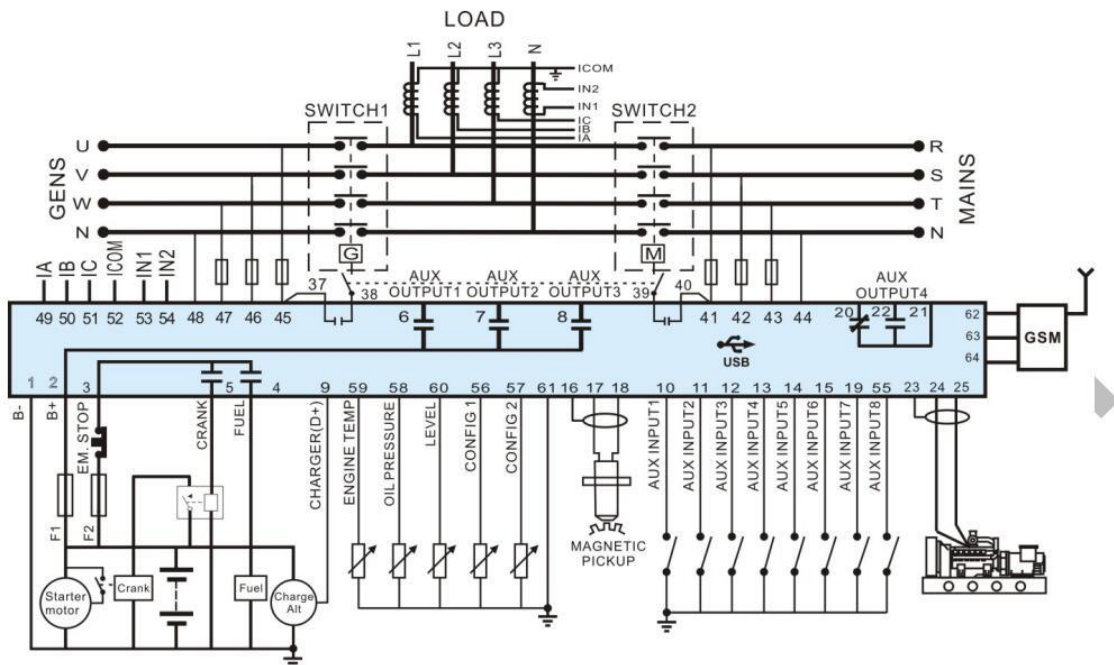

Note: Fuse F1: min. 2A; max. 20A. Fuse F2: max. 32A. Users should select suitable fuse depend on practical application.